

C-100BAE-AD

SELF-CONTAINED CUBELET WITH BUILT-IN STORAGE BIN

Item # _____

Project: _____

Qty: _____

*AutoCad available on KCL

C-100BAE-AD

8/09

Item # 13219

CUBELET DIMENSIONS W x D x H

C-100BAE-AD
14^{7/8} x 22^{5/8} x 31^{1/2}

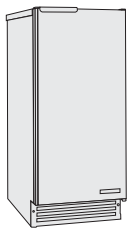

C-100BAE-AD

C-100BAE-AD

Air-Cooled
ADA Compliant Unit
Shown



- Undercounter design is less than 32 inches tall, which complies with the Americans with Disabilities Act (ADA)
- Up to 92 lbs. of ice production per 24 hours
- Durable stainless steel exterior
- UL approval for outdoor use
- Up to 22 lbs. of built-in storage capacity
- Power switch accessible without panel removal
- Easily disassembled water circuit for easy cleaning
- Front in, front out airflow
- Fewer moving parts for longer life
- Swing style reversible door
- Side and top trim kit available
- Drain pump accessory - HS-0190
- R-134A Refrigerant



Warranty

Valid in United States, Canada, Puerto Rico, & U.S. Territories. Contact factory for warranty in other countries.

Two Year - Parts & Labor on entire machine.

One Year - **HS-0190 Drain Pump** - Parts only.



C-100BAE-AD SELF-CONTAINED CUBELET WITH BUILT-IN STORAGE BIN

DIMENSIONS
W x D x H
C-100BAE-AD
14^{7/8} x 22^{5/8} x 31^{1/2}

- Air-cooled
- ADA compliant

AIR-COOLED

Water Temp ° F.	50°	70°	90°
Air Temp ° F. 70°	92	89	84
Air Temp ° F. 80°	81	71	66
Air Temp ° F. 90°	66	64	57

UTILITY CONSUMPTION (AIR 70°F/WATER 50°F)

Model Number	KWH per 100 LBS.	Potable Water Gal. per 100 lbs.	Condenser Water Gal. per 100 lbs.
C-100BAE-AD	8.0	12.0	N/A

SPECIFICATIONS

Model Number	Condenser	Amperage	Min. Circuit Ampacity	Shipping Weight
C-100BAE-AD	Air-Cooled	4.0	15	115 lbs.*

* Without pallet

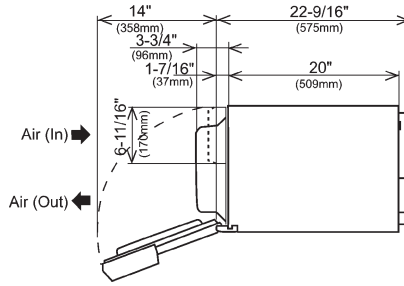

TOP DIMENSIONS

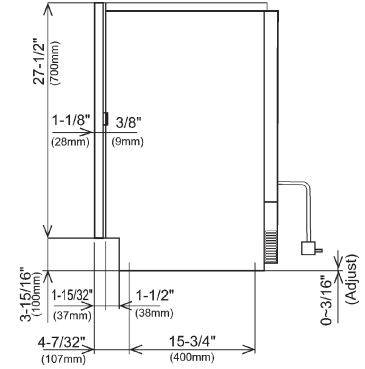

SIDE DIMENSIONS
(ADA compliant unit)

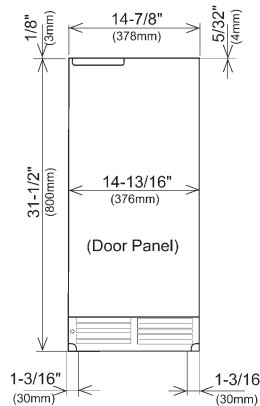

FRONT DIMENSIONS
(ADA compliant unit)

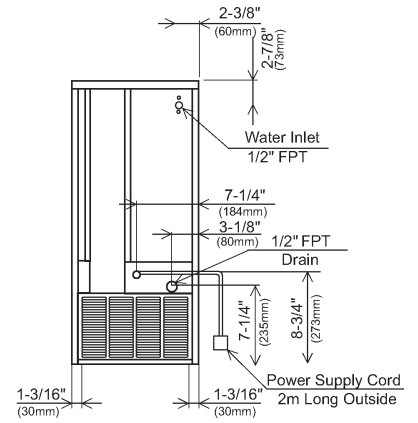

BACK DIMENSIONS
(ADA compliant unit)

ELECTRICAL & PLUMBING/C-100BAE-AD

- 115V/60/1
- 15 amp Max Fuse/HACR Breaker Size
- 1/2" FPT Water Inlet
- 1/2" FPT Drain

OPERATING LIMITS

- Ambient Temp Range 45 - 100°F
- Water Temp Range 45 - 95°F
- Water Pressure 7 - 113psig
- Voltage Range 104 - 127V



© HOSHIZAKI AMERICA, INC.

618 Hwy. 74 S., Peachtree City, GA 30269

TEL 1-800-438-6087

FAX 1-800-345-1325

www.hoshizaki.com

Printed in U.S.A.

