

DCM-270BAH-OS

Item # _____

Project: _____

Qty: _____

*AutoCad available on KCL

OPTISERVE™ SERIES SANITARY CUBELET ICE MACHINE/DISPENSER

DCM-270BAH-OS

8/05

Item # 13159

DIMENSIONS W x D x H

DCM-270BAH-OS

16^{9/16} x 24^{1/8} x 31^{11/16}



DCM-270BAH-OS

Air-Cooled

- CleanCycle 12[®] 
- Durable stainless steel exterior
- Up to 288 lbs. of ice production per 24 hours
- Easy to chew, cubelet ice
- Self contained design reducing opportunities for cross contamination
- Removable air filter
- Stainless steel internal auger
- R-404A



Warranty

Valid in United States, Canada, Puerto Rico, & U.S. Territories. Contact factory for warranty in other countries.

Two Year - Parts & Labor on entire machine.

Five Year - Parts on: hermetic compressor, air-cooled fin and tube type condenser.



DCM-270BAH-OS SANITARY CUBELET ICE MACHINE/DISPENSER OPTISERVE™ SERIES

DIMENSIONS
W x D x H
DCM-270BAH-OS
30 x 11 x 26

AIR-COOLED

Water Temp° F.	50°	70°	90°
Air Temp° F. 70°	288	276	265
80°	254	243	233
90°	224	220	205

UTILITY CONSUMPTION

Model Number	KWH per 100 LBS.		KWH per 100 LBS.	
	90/70	70/50	90/70	70/50
DCM-270BAH-OS	7.3	5.3	12	NA

SPECIFICATIONS

Model Number	Condenser	Amperage	Shipping Weight
DCM-270BAH-OS	Air-Cooled	8.5	166 lbs.

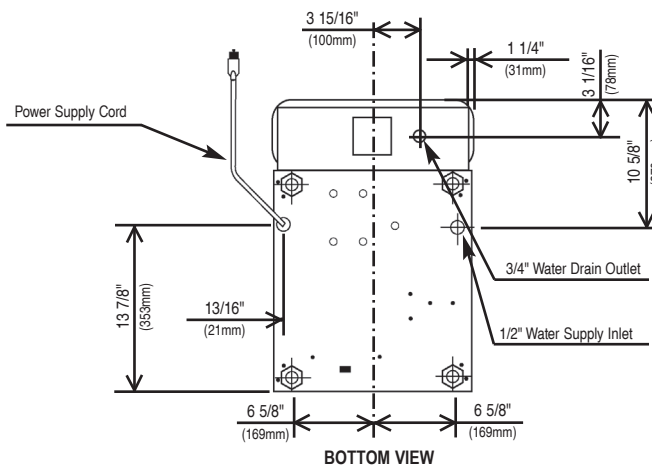
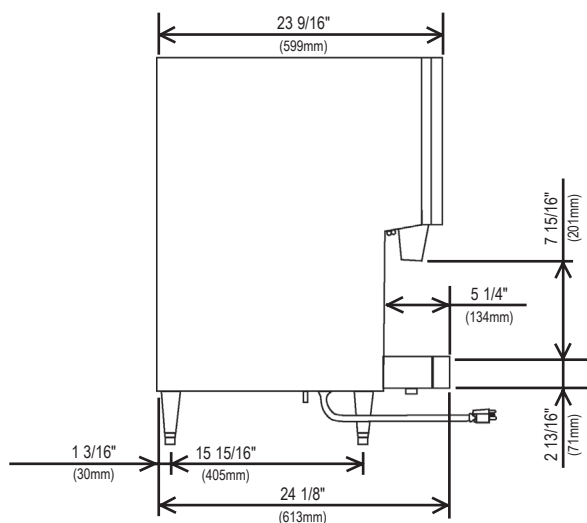
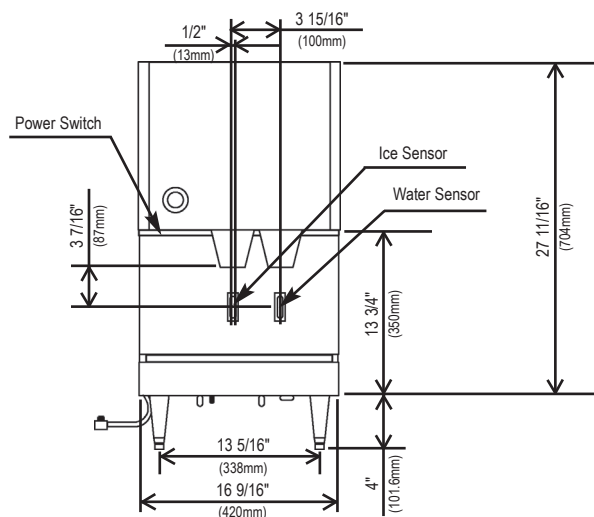

ELECTRICAL & PLUMBING/DCM-270BAH-OS

- 115V/60/1
- 15 amp cord connection

© HOSHIZAKI AMERICA, INC.

OPERATING LIMITS

- Ambient Temp Range 45 - 100°F
- Water Temp Range 45 - 90°F
- Water Pressure 10 - 113psig
- Voltage Range 104 - 127V

SERVICE

- Panels easily removed and all components accessible for service.
- Removable/cleanable air filter.

