

HOSHIZAKI

Series

DCM-270BAH
Item # 13116
4/04

DCM-270BAH SERIES

SANITARY CUBELET ICEMAKER/DISPENSER



DCM-270BAH
Air-Cooled

DCM-270BAH
Counter-Top Cubelet
Dispenser



- CleanCycle 12®
- Durable stainless steel exterior
- Every 12 hours unit performs a 15-minute purge to rid itself of impurities
- Up to 282 lbs. of ice production per 24 hours
- Easy to chew, cubelet ice
- Self contained design reducing opportunities for cross contamination
- Removable air filters

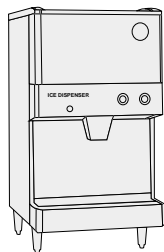

**ICEMAKER
DIMENSION**
Width x Depth x Height
DCM-270BAH
16⁹/₁₆ x 24³/₁₆ x 31⁷/₈"

© HOSHIZAKI AMERICA, INC.

618 Hwy. 74 S., Peachtree City, GA 30269

1-800-438-6087

FAX 1-800-345-1325

TEL 770-487-2331

www.hoshizaki.com



Reliability is a beautiful thing™

SANITARY CUBELET ICEMAKER/DISPENSER



DCM-270BAH (AIR-COOLED)

■ Up to 282 lbs. of ice production per 24 hours

| | | |
|------------------------------------------------------------------------------------------------------------------------------------------------------|--------------------------------------------|------------------------------------------------------------------------------------------------------------------------|
| WARRANTY TWO YEAR - Parts & labor on entire machine. FIVE YEAR - Parts on: Hermetic Compressor, Air-Cooled Fin and Tube type Condenser. | STAINLESS STEEL INTERNAL EVAPORATOR | SERVICE Panels easily removed and all components accessible for service. Removable/cleanable air filters. |
| | R-404 REFRIGERANT | |

Warranty valid in United States and Canada. Contact Factory for Warranty in other Countries, Territories and Possessions.

| OPERATING LIMITS | | ELECTRICAL | | UTILITY CONSUMPTION | | | | |
|--------------------|---------------|------------------------|--|---------------------|------------------|-------|------------------|-------|
| Ambient Temp Range | 45 - 100°F | 115/60/1 | | Model Number | KWH per 100 lbs. | | GAL per 100 lbs. | |
| Water Temp Range | 45 - 90°F | 15 amp cord connection | | | | 90/70 | 70/50 | 90/70 |
| Voltage Range | 104 - 127V | | | DCM-270BAH | 7.6 | 5.5 | 12.0 | 12.0 |
| Water Pressure | 10 - 113 psig | | | | | | | |

Clean Cycle 12™: 15 minute purge every 12 hours

| AIR - COOLED | | | | SPECIFICATIONS | | | |
|-----------------|-----|-----|-----|----------------|------------|----------|-----------------|
| Water Temp ° F. | 50° | 70° | 90° | Model Number | Condenser | Amperage | Shipping Weight |
| Air Temp ° F. | 70° | 282 | 271 | DCM-270BAH | Air-Cooled | 8.5A | 165 lbs. |
| | 80° | 248 | 238 | | | | |
| | 90° | 219 | 215 | | | | |

Separate ice and water dispensing with convenient push button controls

Flaked Ice compacted into Cubelets by Extruding Head Cutter and stored in an Insulated Bin with Continuous Agitation during Dispensing and Direct Dispensing Auger

Evaporator

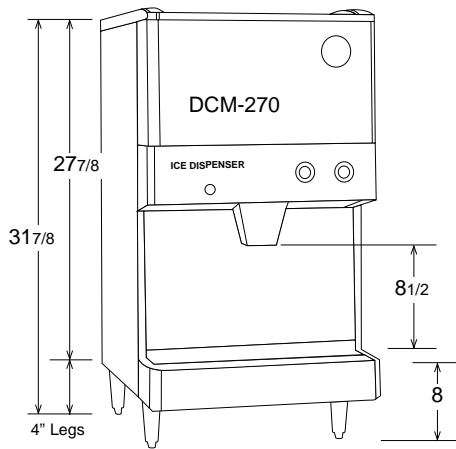
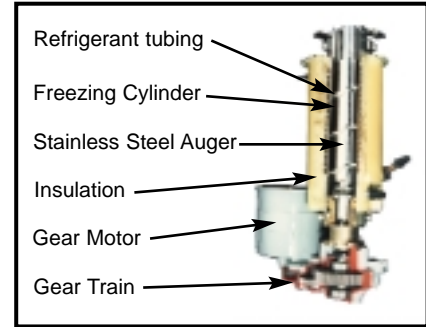
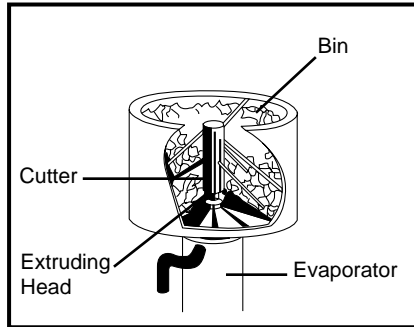
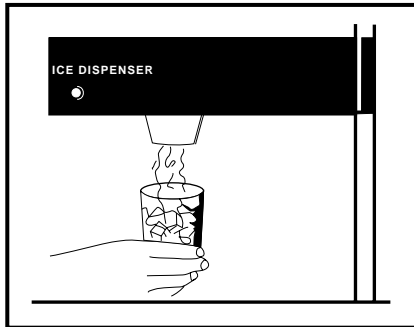

9 lb. Capacity Built-in Bin

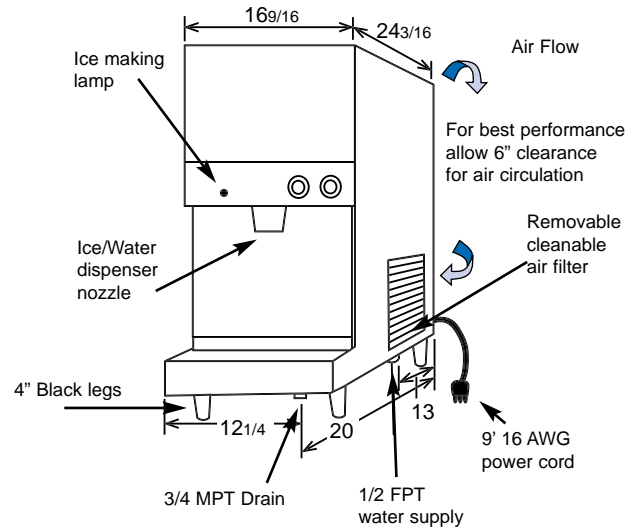

We reserve the right to change specifications without notice.

© HOSHIZAKI AMERICA, INC.