

HOSHIZAKI

DCM-500B_F/SD450 5/04
Item # 13143

DCM-500B_F/SD-450 SERIES

SANITARY CUBELET ICEMAKER/DISPENSER



DCM-500BAF
Air-Cooled
DCM-500BWF
Water-Cooled
SD-450
For DCM-500

DCM-500BAF
on an
optional **SD-450**



DCM-500BAF
Countertop

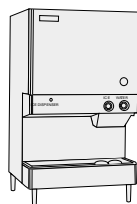

DCM-500BAF
Countertop with
optional 6" legs



DCM-500BAF
Floor Model with
optional stand

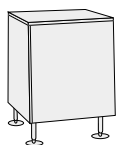

SD-450
optional stand

ICEMAKER DIMENSION	
Width x Depth x Height	
DCM-500BAF	26 x 22 1/2 x 40"
DCM-500 w/ legs*	26 x 22 1/2 x 46"
DIMENSION BY BIN SIZE	
Width x Depth x Height	
DCM-500 w/ stand*	26 x 22 1/2 x 72 1/2"
SD-450 Stand	26 1/4 x 22 x 32 1/2"

* Optional Items

DCM-500B_F



- **CleanCycle 12®**
 - Every 12 hours unit performs a 15-minute purge to rid itself of impurities
 - Up to 567 lbs. of ice production per 24 hours, with 40 lbs. built-in storage
 - Dispenses ice and water
 - Self contained design reducing opportunities for cross contamination
 - Easy to chew, cubelet ice
 - Removable air filters
- SD-450 Stand**
- Heavy duty stand for floor model icemaker/dispenser
 - Corrosion resistant stainless steel exterior
 - Easy cleaning with attractive appearance



Reliability is a beautiful thing™

© HOSHIZAKI AMERICA, INC.

618 Hwy. 74 S., Peachtree City, GA 30269

1-800-438-6087

FAX 1-800-345-1325

TEL 770-487-2331

www.hoshizaki.com

SANITARY CUBELET ICEMAKER/DISPENSER



- DCM-500BAF** (AIR-COOLED)
- DCM-500BWF** (WATER-COOLED)
- SD-450** (FOR DCM-500)

- Up to 567 lbs. of ice production per 24 hours, with 40 lbs. of built-in ice storage
- Dispenses ice and water

WARRANTY TWO YEAR - Parts & labor on entire machine. FIVE YEAR - Parts on: Compressor, Air-Cooled Condenser.	STAINLESS STEEL INTERNAL AUGER	SERVICE Panels easily removed and all components accessible for service. Removable/cleanable air filters.
	R-404 REFRIGERANT	

Warranty valid in United States, Canada, Puerto Rico, & U.S. Territories. Contact Factory for Warranty in other Countries.

OPERATING LIMITS Ambient Temp Range 45 - 100°F Water Temp Range 45 - 90°F Voltage Range 104 - 127V Water Pressure 10 - 113 psig	ELECTRICAL 115/60/1 20 amp Max Fuse Size	STORAGE BIN Built-in 40 lb. capacity	THERMAL RELAY protects gear motor from overload
Clean Cycle 12 ®: 15 minute purge every 12 hours		MACHINE STAND Optional SD-450	GEAR MOTOR runs two minutes after termination of icemaking to clear all ice from evaporator

AIR - COOLED				
Water Temp ° F.	50°	70°	90°	
Air Temp ° F.	70°	525	510	485
	80°	461	438	416
	90°	396	385	358

UTILITY CONSUMPTION				
Model Number	Approximate Electrical		KWH per 100 lbs.	
	90/70	70/50	90/70	70/50
DCM-500BAF	1055W	985W	6.6	4.4
DCM-500BWF	967W	991W	4.7	4.1

WATER - COOLED				
Water Temp ° F.	50°	70°	90°	
Air Temp ° F.	70°	567	549	539
	80°	529	519	509
	90°	500	495	481

SPECIFICATIONS				
Model Number	Condenser	Amperage	Min Circuit Ampacity	Shipping Weight
DCM-500BAF	Air-Cooled	12	20	290 lbs.
DCM-500BWF	Water-Cooled	11.5	20	290 lbs.
SD-450	N/A	N/A	N/A	110 lbs.

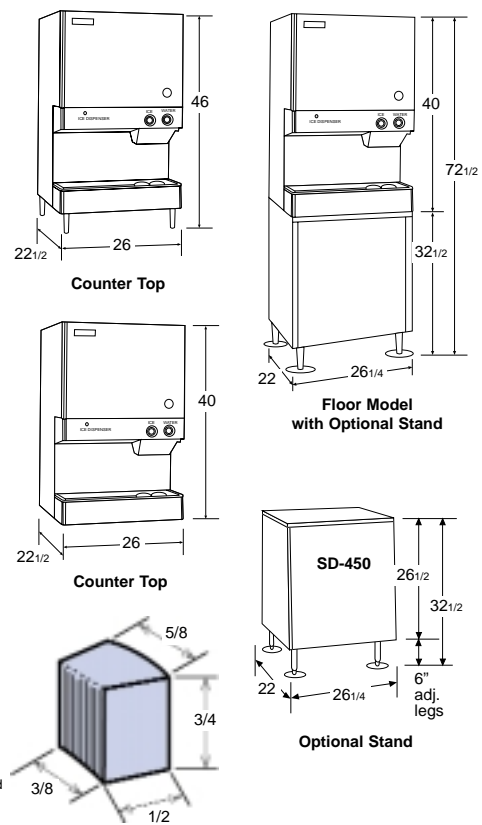
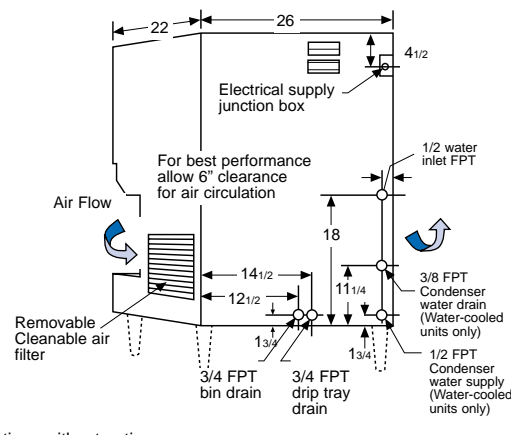
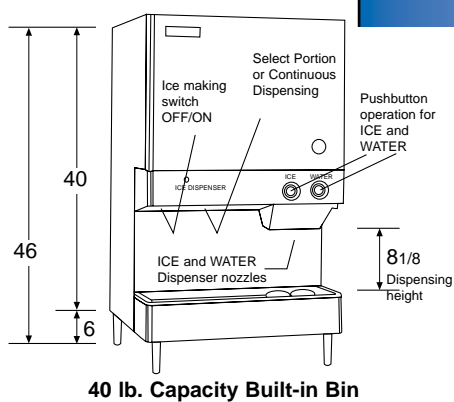
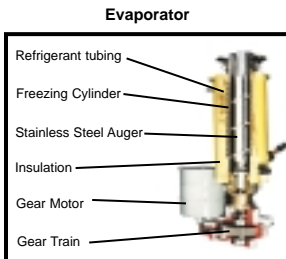
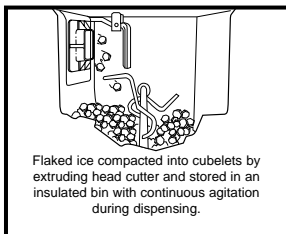
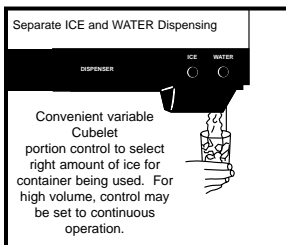

We reserve the right to change specifications without notice.

© HOSHIZAKI AMERICA, INC.