

IM-500SAA

STACKABLE SQUARE CUBER

Item # _____

Project: _____

Qty: _____

*AutoCad available on KCL

IM-500SAA

5/13

Item # 13320

CUBER DIMENSIONS

W x D x H

IM-500SAA
44 x 27^{5/8} x 21^{3/4}

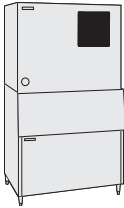

B-700

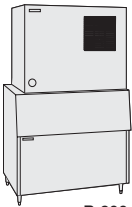

B-800

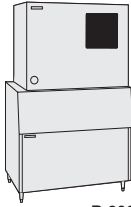

B-900

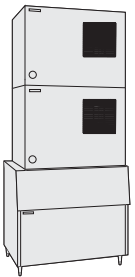

B-800

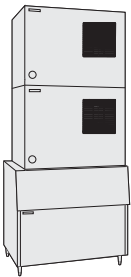

B-900

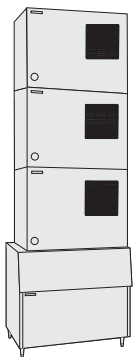

B-800

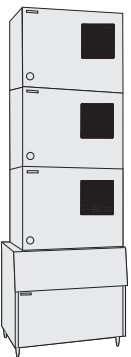

B-900

IM-500SAA
Air-Cooled
Shown on an optional
B-700 Bin



- Up to 500 lbs. of ice production per 24 hours
- Durable stainless steel exterior
- Air filter easily removable from front of unit
- Individual square cube
- Stackable 2 units high for 1000 lbs. per 24 hour ice production in the same floor space (Stacking Kit: S25691 required)
- Stackable up to 3 units high for 1500 lbs. per 24 hour ice production in the same floor space (Two Stacking Kits: S25691 required)
- EverCheck® digital control system with LED display 
- R-404A Refrigerant

* The IM-500SAA is ENERGY STAR qualified

Warranty

Valid in United States, Canada, Puerto Rico, & U.S. Territories. Contact factory for warranty in other countries.

Three Year - Parts & Labor on entire machine.

Five Year - Parts on: Compressor, air-cooled condenser coil.



ISO 9001-15014001



Hoshizaki

DIMENSIONS
W x D x H
IM-500SAA
44 x 27^{5/8} x 21^{3/4}

CUBER ICE MACHINE

• Air-cooled

IM-500SAA
STACKABLE SQUARE CUBER

AIR-COOLED

Water Temp ° F.	50°	70°	90°	
Air Temp ° F.	70°	500	481	447
	80°	485	456	417
	90°	481	435	397

UTILITY CONSUMPTION

Model Number	Ice Production Per Cycle		KWH per 100 LBS. 90/70	Water Gal. per 100 lbs. 90/70
	Lbs.	Cubes		
IM-500SAA	6.9	140	5.45	19.8

SPECIFICATIONS

Model Number	Condenser	Amperage	Min. Circuit Ampacity	Shipping Weight
IM-500SAA	Air-Cooled	11.5	20	220 lbs.

STORAGE BINS

Model Number	Application Capacity	ARI-Rated Capacity
B-700	700 lbs.	550 lbs.
B-800	800 lbs.	600 lbs.
B-900	900 lbs.	660 lbs.

***IM CUBE DIMENSIONS**

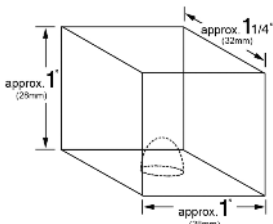

*approximate size, image not to scale

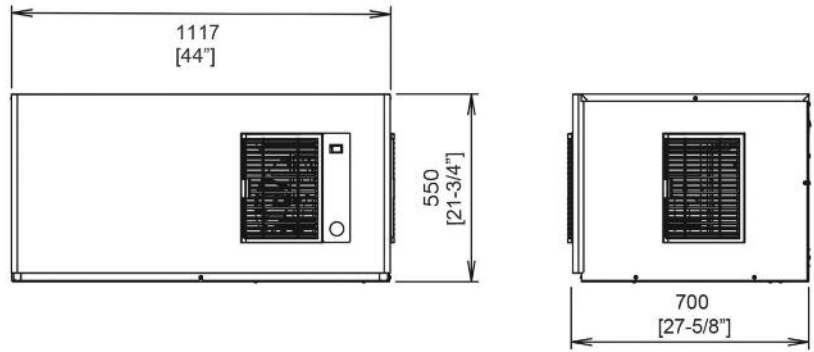

FRONT VIEW

SIDE VIEW

Air Flow
For proper air circulation allow 6" clearance at rear, left side and top of the unit and allow 12" clearance on right side of the unit

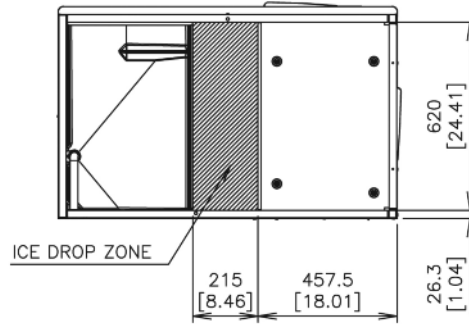

ICE DROP ZONE (BOTTOM VIEW)

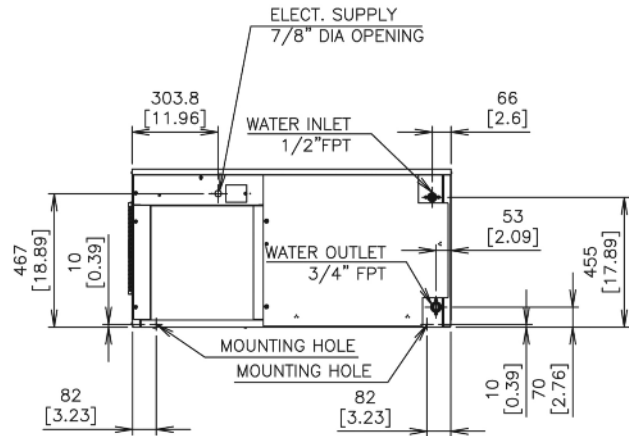

AIR-COOLED UNIT (REAR VIEW)

ELECTRICAL & PLUMBING/IM-500SAA

- 115/60/1
- 20 amp Max Fuse/HACR Breaker Size
- 1/2" FPT water inlet
- 3/4" FPT water drain

OPERATING LIMITS

- Ambient Temp Range 45 - 100°F
- Water Temp Range 45 - 90°F
- Water Pressure 10 - 113psig
- Voltage Range 104 - 127V

SERVICE

- Panels easily removed and all components accessible for service.
- Removable/cleanable air filters.



© HOSHIZAKI AMERICA, INC.

618 Hwy. 74 S., Peachtree City, GA 30269

TEL 1-800-438-6087

FAX 1-800-345-1325

www.hoshizaki.com

Printed in U.S.A.

