

Item # _____

Project: _____

Qty: _____

*AutoCad available on KCL

AM-50BAE-(AD)DS

SELF-CONTAINED CUBER WITH BUILT-IN STORAGE BIN (ADA Compliant with Customized Door System)

AM-50BAE-DS

12/12

Item # 13172

CUBER DIMENSIONS W x D x H

AM-50BAE

14^{7/8} x 22^{5/8} x 33^{1/2}

AM-50BAE-AD

14^{7/8} x 22^{5/8} x 31^{1/2}

AM-50BAE-DS

14^{7/8} x 22^{5/8} x 33^{1/2}

AM-50BAE-ADDS

14^{7/8} x 22^{5/8} x 31^{1/2}

*DS - Designed to accommodate custom cabinetry to affix to stainless steel.

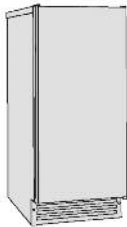

AM-50BAE-DS

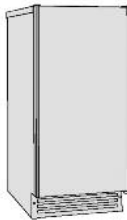

AM-50BAE-(AD)DS

AM-50BAE

Air-Cooled
Shown

AM-50BAE-AD

Air-Cooled
ADA Compliant Unit



AM-50BAE-DS*

Air-Cooled
Shown
with Custom Cabinetry

AM-50BAE-ADDS*

Air-Cooled
ADA Compliant Unit



*Customer responsible for providing cabinetry

AM-50BAE & AM-50BAE-DS

- Undercounter design is less than 34 inches tall

AM-50BAE-AD & AM-50BAE-ADDS

- Undercounter design is less than 32 inches tall, which complies with the Americans with Disabilities Act (ADA)

AM-50BAE(-DS) & AM-50BAE-AD(DS)

- Up to 55 lbs. of ice production per 24 hours
- UL approval for outdoor use
- Up to 22 lbs. of built-in storage capacity
- Power switch accessible without panel removal
- Easily disassembled water circuit for easy cleaning
- Front in, front out airflow
- Fewer moving parts for longer life
- Swing style reversible door
- Optional kit required for “- DS” models
- Side trim kit available
- Accessory - HS-506I Drain Pump Assembly
- R-134A Refrigerant

Warranty

Valid in United States, Canada, Puerto Rico, & U.S. Territories. Contact factory for warranty in other countries.

Two Year - Parts & Labor on entire machine.

One Year - HS-506I Drain Pump Assembly - Parts & Labor.



© HOSHIZAKI AMERICA, INC.

618 Hwy. 74 S., Peachtree City, GA 30269

TEL 1-800-438-6087

FAX 1-800-345-1325

www.hoshizaki.com



AM-50BAE-(AD)DS*

SELF-CONTAINED CUBER WITH BUILT-IN STORAGE BIN

*DS - Designed to accommodate custom cabinetry to affix to stainless door.

DIMENSIONS

W x D x H

AM-50BAE / AM-50BAE-DS
14^{7/8} x 22^{5/8} x 33^{1/2}

AM-50BAE-AD / AM-50BAE-ADDS
14^{7/8} x 22^{5/8} x 31^{1/2}

- Air-cooled
- Air-cooled, ADA compliant

AIR-COOLED

Water Temp ° F.	50°
Air Temp ° F.	70°
	55 lbs.

UTILITY CONSUMPTION (AIR 70°F/WATER 50°F)

Model Number	Ice Production Per Cycle Lbs. Cubes	KWH per 100 LBS.	Potable Water Gal. per 100 lbs.	Condenser Water Gal. per 100 lbs.
AM-50BAE-(AD)DS	0.65 24	9.9	53.7	N/A

SPECIFICATIONS

Model Number	Condenser	Amperage	Min. Circuit Ampacity	Shipping Weight
AM-50BAE-(AD)DS	Air-Cooled	3.4	15	115 lbs.*

* Without pallet

AM CUBE DIMENSIONS

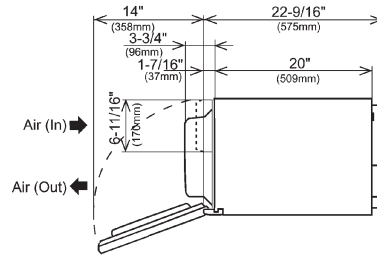
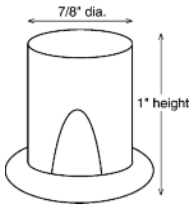

TOP DIMENSIONS

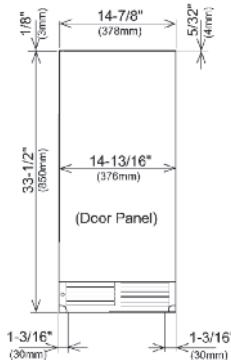

FRONT DIMENSIONS

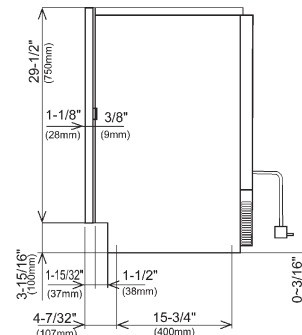

SIDE DIMENSIONS

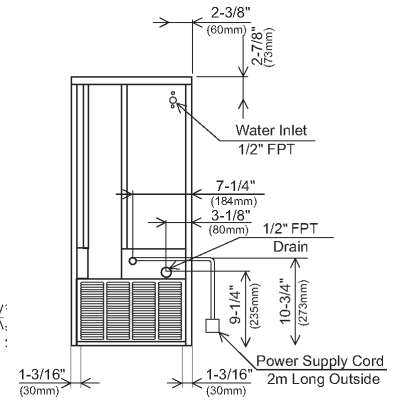

BACK DIMENSIONS

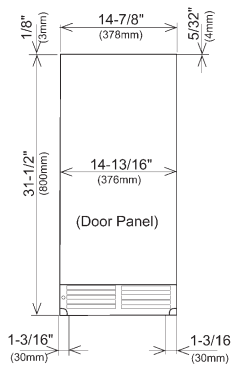

FRONT DIMENSIONS
(ADA compliant unit)

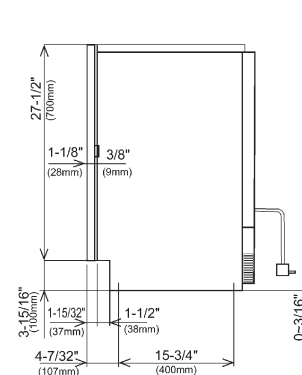

SIDE DIMENSIONS
(ADA compliant unit)

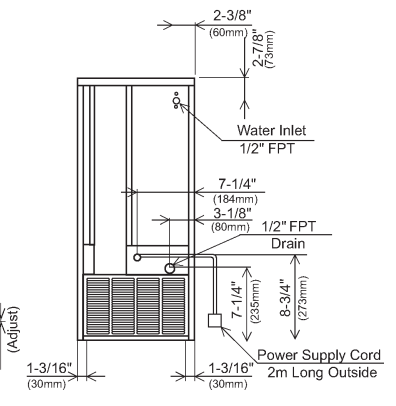

BACK DIMENSIONS
(ADA compliant unit)

ELECTRICAL & PLUMBING

- 115V/60/1ø
- 15 amp Max Fuse
- 1/2" FPT Water Inlet
- 1/2" FPT Drain



1509300 | ISO 14001

© HOSHIZAKI AMERICA, INC.

618 Hwy. 74 S., Peachtree City, GA 30269

OPERATING LIMITS

- Ambient Temp Range 45 - 100°F
- Water Temp Range 45 - 95°F
- Water Pressure 7 - 113psig
- Voltage Range 104 - 127V

OPTIONS

- Side trim kit available

TEL 1-800-438-6087

FAX 1-800-345-1325

www.hoshizaki.com

Printed in U.S.A.

