

KM-61BAH

SELF-CONTAINED CUBER WITH BUILT-IN STORAGE BIN

Item # _____

Project: _____

Qty: _____

*AutoCad available on KCL

KM-61BAH

12/12

Item # 13216

CUBER DIMENSIONS W x D x H

KM-61BAH

17^{3/4} x 24 x 39*

* with 6" legs



KM-61BAH

Air-Cooled
Shown

- Up to 71 lbs. of ice production per 24 hours
- Up to 38 lbs. of built-in storage capacity
- Individual crescent cube
- Durable stainless steel exterior
- CycleSaver® Design 
- EverCheck® alert system 
- Front in, front out airflow
- Stainless steel evaporator
- Slide in door
- Removable air filter
- Power switch accessible without panel removal
- Built-in installation possible
- Accessory - HS-506I Drain Pump Assembly
- R-134a Refrigerant

* The KM-61BAH is ENERGY STAR qualified.



Warranty

Valid in United States, Canada, Puerto Rico, & U.S. Territories. Contact factory for warranty in other countries.

Three Year - Parts & Labor on entire machine.

Five Year - Parts on compressor and air-cooled condenser coil.

Five Year - Parts on evaporator.

One Year - HS-506I Drain Pump Assembly - Parts & Labor.

© HOSHIZAKI AMERICA, INC.

618 Hwy. 74 S., Peachtree City, GA 30269

TEL 1-800-438-6087

FAX 1-800-345-1325

www.hoshizaki.com



Hoshizaki

SELF-CONTAINED CUBER WITH BUILT-IN STORAGE BIN

DIMENSIONS

W x D x H

KM-61BAH
17^{3/4} x 24 x 39*
*with 6" legs

• Air-cooled

AIR-COOLED

Water Temp ° F.	50°	70°	90°
Air Temp ° F. 70°	71	65	58
80°	66	57	51
90°	65	50	44

UTILITY CONSUMPTION

Model Number	Ice Production Per Cycle		KWH per 100 LBS.	Potable Water Gal. per 100 lbs.	Condenser Water Gal. per 100 lbs.
	Lbs.	Cubes			
KM-61BAH	1.7	80	10.6	20.6	N/A

SPECIFICATIONS

Model Number	Condenser	Amperage	Min. Circuit Ampacity	Shipping Weight
KM-61BAH	Air-Cooled	3.4	15A	117 lbs.

KM CUBE DIMENSIONS

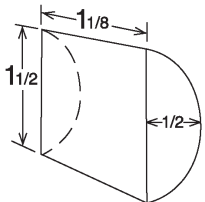

FRONT DIMENSIONS

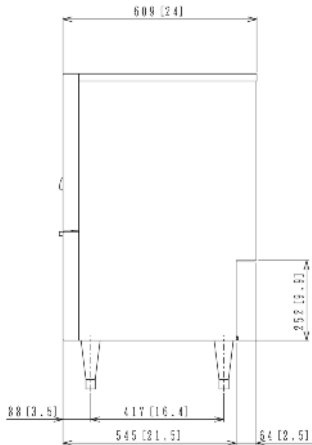

SIDE DIMENSIONS

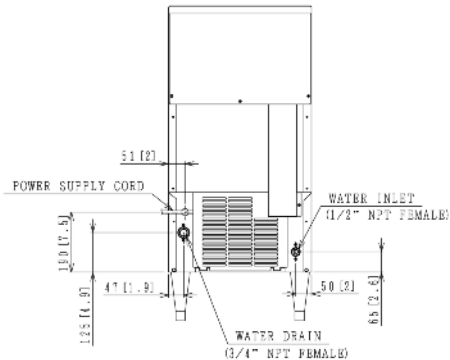

BACK DIMENSIONS

ELECTRICAL & PLUMBING/KM-61BAH

- 115V/60/1
- 15 amp Max Fuse/HACR Breaker Size
- 3/8" OD copper or equivalent independent potable water supply
- 3/4" independent drain connection
- 1/2" FPT Water Inlet



© HOSHIZAKI AMERICA, INC.

618 Hwy. 74 S., Peachtree City, GA 30269

OPERATING LIMITS

- Ambient Temp Range 45 - 100°F
- Water Temp Range 45 - 90°F
- Water Pressure 10 - 113psig
- Voltage Range 104 - 127V

TEL 1-800-438-6087

FAX 1-800-345-1325

www.hoshizaki.com

Printed in U.S.A.

