

# KM-650M\_H

## SLIM-LINE MODULAR CRESCENT CUBER

Item # \_\_\_\_\_

Project: \_\_\_\_\_

Qty: \_\_\_\_\_  
 \*AutoCad available on KCL

KM-650M\_H

I/13

Item # 13191

### CUBER DIMENSIONS

W x D x H

**KM-650M\_H**  
 22 x 27<sup>3/8</sup> x 37<sup>7/16</sup>



B-300



B-500



B-700



B-800

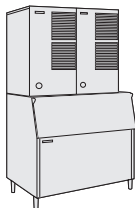

B-900

Also available on Large Bins:  
 B-1150SS  
 B-1300SS  
 B-1500SS  
 B-1650SS

### KM CUBE DIMENSIONS

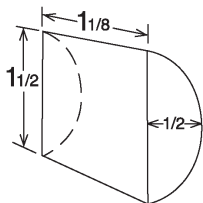

### KM-650MAH



Air-Cooled  
 Shown on an optional  
 B-300 Bin

### KM-650MWH

Water-Cooled

### KM-650MRH

Remote Air-Cooled

- Up to 66l lbs. of ice production per 24 hours
- Durable stainless steel exterior
- Protected by H-GUARD Plus Antimicrobial Agent 
- Individual crescent cube
- CycleSaver® Design 
- EverCheck® alert system 
- Stainless steel evaporator
- Mount two units side-by-side, in only 44" of floor space, for 1,322 lbs. per 24 hours
- Removable air filters (Air-cooled model only)
- R-404A Refrigerant

\* The KM-650MAH is ENERGY STAR qualified.

### Warranty

Valid in United States, Canada, Puerto Rico, & U.S. Territories. Contact factory for warranty in other countries.

**Three Year** - Parts & Labor on entire machine.

**Five Year** - Parts & Labor on: Evaporator.

**Five Year** - Parts on: Compressor, air-cooled condenser coil.



15070011-5/31/00E

# Hoshizaki

# KM-650M\_H SLIM-LINE MODULAR CRESCENT CUBER

**DIMENSIONS**  
W x D x H  
**KM-650M\_H**  
22 x 27<sup>3/8</sup> x 37<sup>7/16</sup>

- Air-cooled
- Water-cooled
- Remote Air-cooled

### AIR-COOLED

Water Temp ° F.	50°	70°	90°	
Air Temp ° F.	70°	661	632	591
80°	639	594	553	
90°	632	<b>562</b>	520	

### WATER-COOLED

Water Temp ° F.	50°	70°	90°	
Air Temp ° F.	70°	661	649	616
80°	652	633	591	
90°	649	<b>620</b>	581	

### AIR-COOLED REMOTE

Water Temp ° F.	50°	70°	90°	
Air Temp ° F.	70°	632	612	574
80°	617	586	541	
90°	612	<b>564</b>	521	

### UTILITY CONSUMPTION

Model Number	Ice Production Per Cycle		KWH per 100 LBS. 90/70	Potable Water Gal. per 100 lbs.	Condenser Water Gal. per 100 lbs.
	Lbs.	Cubes			
KM-650MAH	14.6	720	5.51	18.0	N/A
KM-650MWH	14.2	720	4.10	22.3	120
KM-650MRH	14.4	720	5.6	16.5	N/A

### SPECIFICATIONS

Model Number	Condenser	Amperage	Min. Circuit Ampacity	Shipping Weight
KM-650MAH	Air-Cooled	7.2	15 A	200 lbs.
KM-650MWH	Water-Cooled	5.4	15 A	200 lbs.
KM-650MRH	Remote Air-Cooled	7.4	15 A	200 lbs.

### STORAGE BINS

Model Number	Application Capacity	ARI-Rated Capacity
B-300	300 lbs.	260 lbs.
B-500	500 lbs.	360 lbs.
B-700	700 lbs.	550 lbs.
B-800	800 lbs.	600 lbs.
B-900	900 lbs.	660 lbs.
B-1150	1150 lbs.	N/A
B-1300	1275 lbs.	N/A
B-1500	1490 lbs.	N/A
B-1650	1605 lbs.	N/A

### ELECTRICAL & PLUMBING/KM-650M\_H

- 208-230/60/1 (3 wire with dedicated neutral for 115V)
- 15 Amp Max Fuse/HACR Breaker Size
- 3/8" OD copper or equivalent independent potable water supply
- 3/4" FPT independent drain connection



© HOSHIZAKI AMERICA, INC.

618 Hwy. 74 S., Peachtree City, GA 30269

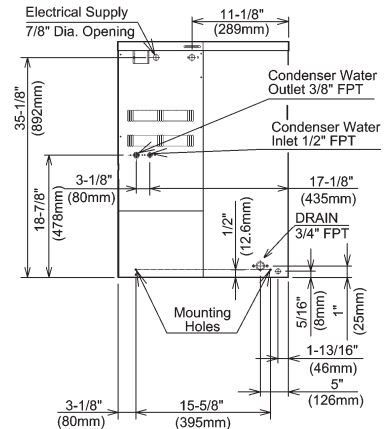
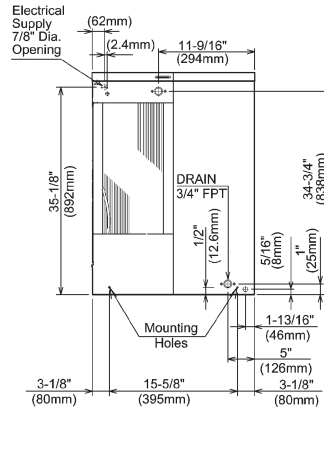
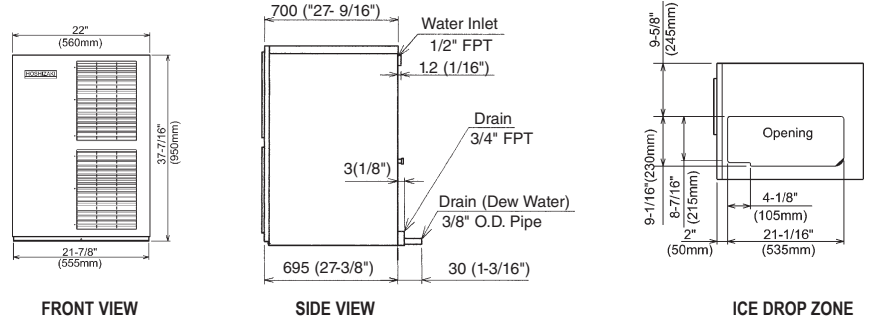

AIR-COOLED UNIT

WATER-COOLED UNIT

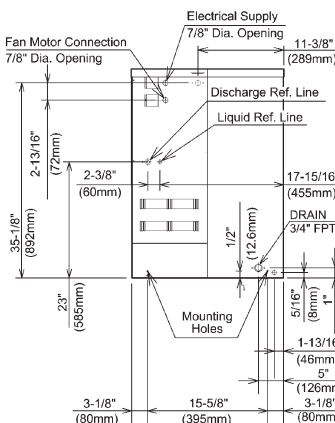

REMOTE AIR-COOLED UNIT

### URC-5F Remote Condenser (Sold Separately)

Voltage supply for the URC Remote Condenser is supplied from the Ice Maker. No additional circuit is required.

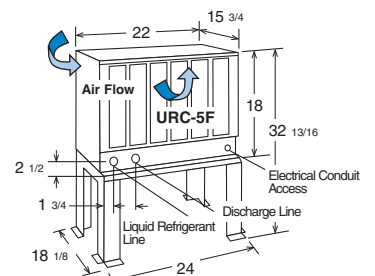

### Pre-Charged Tubing Kits

(Sold Separately)  
20' R404-2046-2  
35' R404-3546-2



### OPERATING LIMITS

- Ambient Temp Range 45 - 100°F
- Water Temp Range 45 - 90°F
- Water Pressure 10 - 113psig
- Voltage Range 187 - 253V

### OPERATING LIMITS/URC-5F

- Ambient Temp Range -20°F - +122°F
- Voltage Range 104 - 127V

### SERVICE

- Panels easily removed and all components accessible for service.
- Removable/cleanable air filters. (Air-cooled model only)

TEL 1-800-438-6087

FAX 1-800-345-1325

www.hoshizaki.com

Printed in U.S.A.

