

C-101BAH-(AD)DS*

SELF-CONTAINED CUBELET WITH BUILT-IN STORAGE BIN (ADA Compliant with Customized Door System)

Item # _____

Project: _____

Qty: _____

*AutoCad available on KCL

C-101BAH-(AD)DS

7/13

Item # 13324

CUBELET DIMENSIONS

W x D x H

C-101BAH

14^{7/8} x 22^{5/8} x 33^{1/2}

C-101BAH-AD

14^{7/8} x 22^{5/8} x 31^{1/2}

C-101BAH-DS

14^{7/8} x 22^{5/8} x 33^{1/2}

C-101BAH-ADDS

14^{7/8} x 22^{5/8} x 31^{1/2}

*DS - Designed to accommodate custom cabinetry to affix to stainless door.

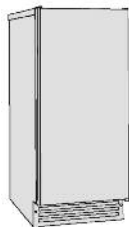

C-101BAH-(DS)

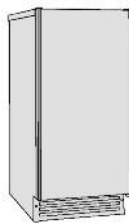

C-101BAH-AD(DS)

C-101BAH

Air-Cooled
Shown

C-101BAH-AD

Air-Cooled
ADA Compliant Unit



C-101BAH-DS*

Air-Cooled
Shown
with Custom Cabinetry

C-101BAH-ADDS*

Air-Cooled
ADA Compliant Unit



*Customer responsible for providing cabinetry

C-101BAH & C-101BAH-DS

- Undercounter design is less than 34 inches tall

C-101BAH-AD & C-101BAH-ADDS

- Undercounter design is less than 32 inches tall, which complies with the Americans with Disabilities Act (ADA)

C-101BAH-(DS) & C-101BAH-AD(DS)

- Up to 92 lbs. of ice production per 24 hours, up to 22 lbs. of built-in storage capacity
- Easy to chew, cubelet ice
- UL approval for outdoor use
- Front access and electronic parts provide ease of cleaning and maintenance
- Swing style reversible door
- Side and top trim kit available
- Accessory - HS-506I Drain Pump Assembly - with designated mounting inside machine
- R-134A Refrigerant

* The C-101BAH, C-101BAH-AD, C-101BAH-(DS) and C-101BAH-AD(DS) are ENERGY STAR qualified.



ISO9001-15014:2001

Warranty

Valid in United States, Canada, Puerto Rico, & U.S. Territories. Contact factory for warranty in other countries.

Two Year - Parts & Labor on entire machine.

One Year - HS-506I Drain Pump Assembly - Parts & Labor.



C-101BAH-(AD)DS SELF-CONTAINED CUBELET WITH BUILT-IN STORAGE BIN

DIMENSIONS W x D x H

C-101BAH / C-101BAH-DS
14^{7/8} x 22^{5/8} x 33^{1/2}

C-101BAH-AD / C-101BAH-ADDS
14^{7/8} x 22^{5/8} x 31^{1/2}

- Air-cooled
- ADA compliant

AIR-COOLED

Water Temp ° F.	50°	70°	90°
Air Temp ° F.	70°	89	84
	80°	71	66
	90°	66	57

UTILITY CONSUMPTION (AIR 70°F/WATER 50°F)

Model Number	KWH per 100 LBS.	Potable Water Gal. per 100 lbs.	Condenser Water Gal. per 100 lbs.
C-101BAH-(AD)DS	12.1	12	N/A

SPECIFICATIONS

Model Number	Condenser	Amperage	Min. Circuit Ampacity	Shipping Weight
C-101BAH-(AD)DS	Air-Cooled	4.0	15	120 lbs.

*CUBELET DIMENSIONS

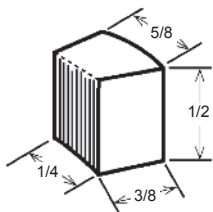

*approximate size
image not to scale

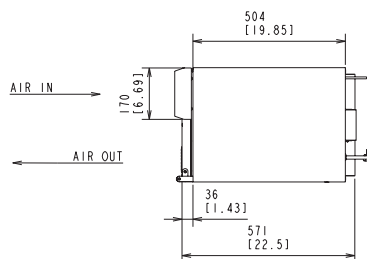

TOP DIMENSIONS

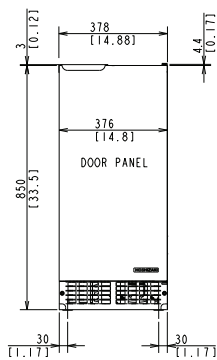

FRONT DIMENSIONS

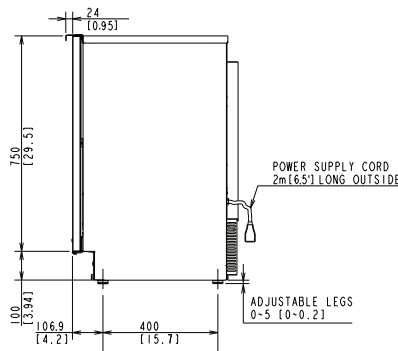

SIDE DIMENSIONS

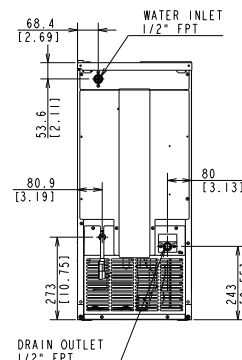

BACK DIMENSIONS

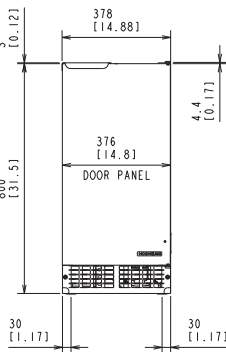

FRONT DIMENSIONS
(ADA compliant unit)

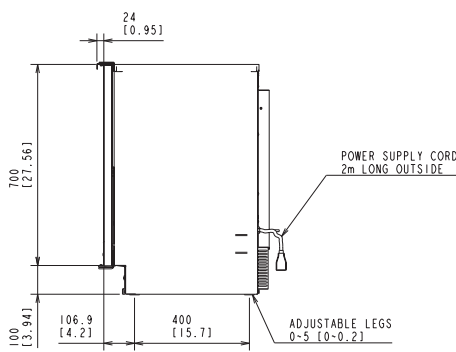

SIDE DIMENSIONS
(ADA compliant unit)

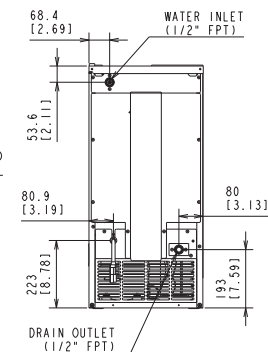

BACK DIMENSIONS
(ADA compliant unit)

ELECTRICAL & PLUMBING/C-101BAH-AD(DS)

- 115V/60/1
- 15 amp Max Fuse/HACR Breaker Size
- 1/2" FPT Water Inlet
- 1/2" FPT Drain



© HOSHIZAKI AMERICA, INC.

618 Hwy. 74 S., Peachtree City, GA 30269

OPERATING LIMITS

- Ambient Temp Range 45 - 100°F
- Water Temp Range 45 - 90°F
- Water Pressure 7 - 113psig
- Voltage Range 104 - 127V

TEL 1-800-438-6087

FAX 1-800-345-1325

www.hoshizaki.com

Printed in U.S.A.

