

# DCM-500B\_H-OS

## OPTI-SERVE SERIES

### SANITARY CUBELET ICE MACHINE/DISPENSER

Item # \_\_\_\_\_

Project: \_\_\_\_\_

Qty: \_\_\_\_\_

\*AutoCad available on KCL

DCM-500B\_H-OS

9/13

Item # 13147

#### DIMENSIONS

W x D x H

**DCM-500B\_H-OS**  
26 x 22<sup>1/2</sup> x 40

**SD-450**  
26<sup>1/4</sup> x 22 x 32<sup>1/2</sup>

**SD-500**  
25<sup>9/10</sup> x 22 x 32<sup>3/4</sup>

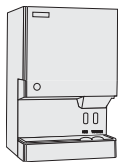

**DCM-500**  
Countertop



**DCM-500**  
Countertop  
with optional  
6" legs

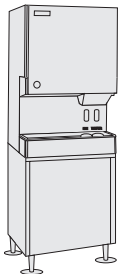

**DCM-500**  
Floor Model  
with optional  
stand

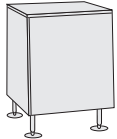

**SD-450**  
optional  
stand

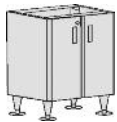

**SD-500**  
optional  
stand

#### DCM-500BAH-OS

Air-Cooled  
Shown on an optional  
**SD-500 Stand**



#### DCM-500BWH-OS

Water-Cooled



\*Transparent drinkware may affect dispensing operations

#### DCM-500B\_H-OS

- CleanCycle 12® - Every 12 hours, unit performs 15 minute purge to rid itself of impurities 
- LED Remote sensor for hands-free operation
- Sealed LED housing prevents moisture from entering, eliminating the possibility of an electrical short
- Corrosion resistant stainless steel exterior
- Up to 618 lbs. of ice production per 24 hours, with 40 lbs. built-in storage
- Easy to chew, cubelet ice
- Self contained design reducing opportunities for cross contamination
- Dispenses ice and water
- Removable air filters (Air-cooled model only)
- Protected by H-GUARD Plus Antimicrobial Agent 

#### SD-450 Stand / SD-500 Stand

- Heavy duty stand for floor model icemaker/dispenser
- Corrosion resistant stainless steel exterior
- Easy cleaning with attractive appearance
- Locking doors standard on SD-500



ISO9001-ISO14001

#### Warranty

Valid in United States, Canada, Puerto Rico, & U.S. Territories. Contact factory for warranty in other countries.

**Three Year** - Parts & Labor on entire machine. (Serial numbers Vxxxxxj) and after.)

**Five Year** - Parts on: Compressor, air-cooled condenser.



# DCM-500B\_H-OS SANITARY CUBELET ICE MACHINE/DISPENSER - OPTI-SERVE SERIES

**DIMENSIONS**  
W x D x H

<b>DCM-500B_H-OS</b>	26" x 22 1/2" x 40"
<b>SD-450</b>	26 1/4" x 22" x 32 1/2"
<b>SD-500</b>	25 9/10" x 22" x 32 3/4"

- Hands-free ice machine/dispenser
- Optional stand
- Optional stand with locking doors

## AIR-COOLED

Water Temp ° F.	50°	70°	90°	
Air Temp ° F.	70°	618	590	561
	80°	534	509	484
	90°	461	450	418

## WATER-COOLED

Water Temp ° F.	50°	70°	90°	
Air Temp ° F.	70°	567	549	539
	80°	529	519	509
	90°	500	495	481

## UTILITY CONSUMPTION

Model Number	Approximate Electrical		KWH per 100 LBS.	
	90/70	70/50	90/70	70/50
DCM-500BAH-OS	1055W	989W	5.62	4.02
DCM-500BWH-OS	930W	985W	4.8	4.0

## SPECIFICATIONS

Model Number	Condenser	Amperage	Min. Circuit Ampacity	Shipping Weight
DCM-500BAH-OS	Air-Cooled	12.9	20	290 lbs.
DCM-500BWH-OS	Water-Cooled	11.5	20	290 lbs.
SD-450	N/A	N/A	N/A	110 lbs.
SD-500	N/A	N/A	N/A	98 lbs.

## \*CUBELET DIMENSIONS

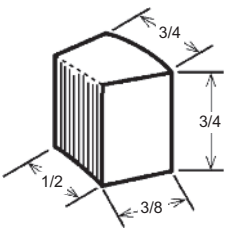

\*approximate size in inches, image not to scale

## ELECTRICAL & PLUMBING/DCM-500BAH-OS

- 115V/60/1
- 20 amp Max Fuse Size
- 1/2" OD copper or equivalent independent water supply
- 3/4" independent drain connection



© HOSHIZAKI AMERICA, INC.

618 Hwy. 74 S., Peachtree City, GA 30269

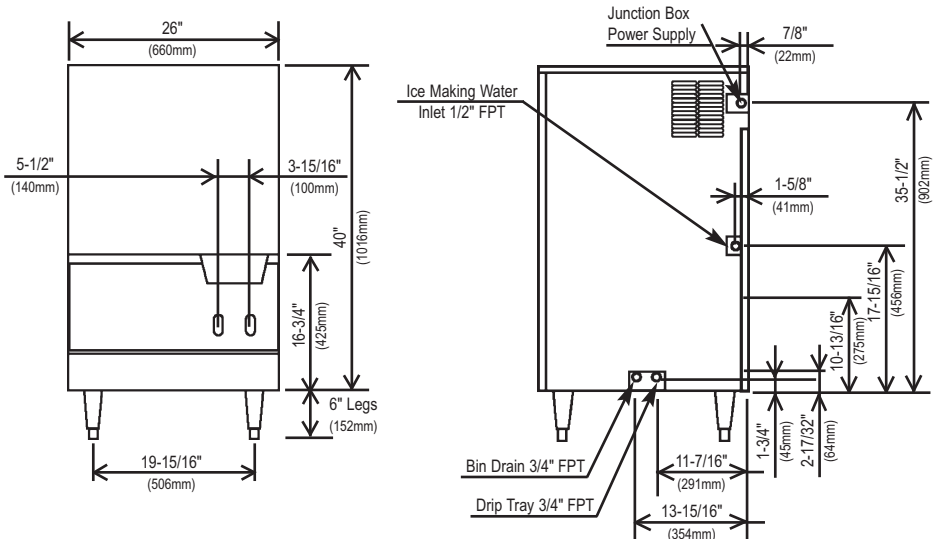

FRONT VIEW

AIR-COOLED UNIT

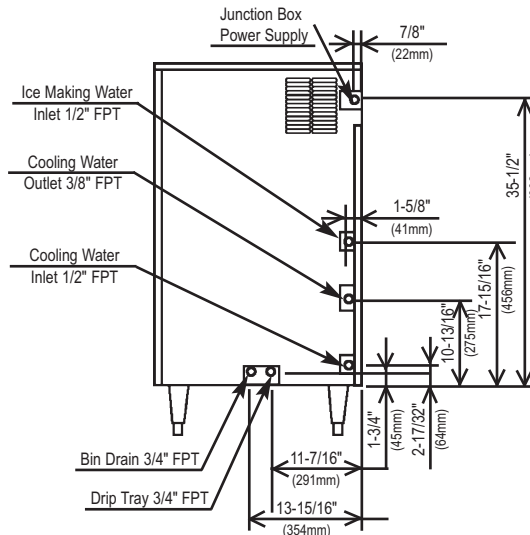

WATER-COOLED UNIT

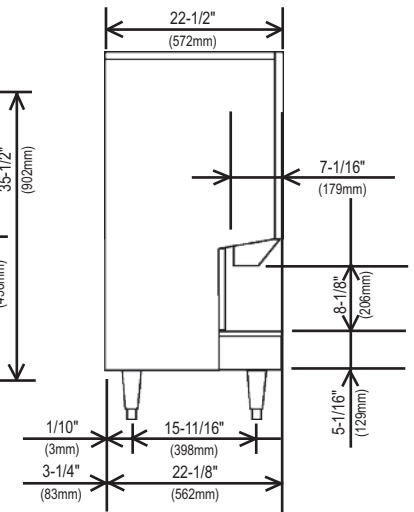

SIDE VIEW

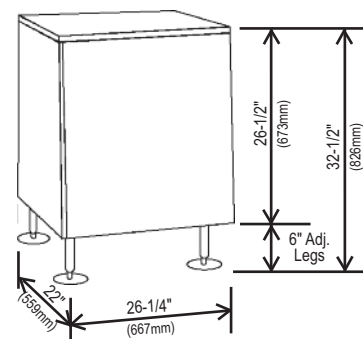

SD-450

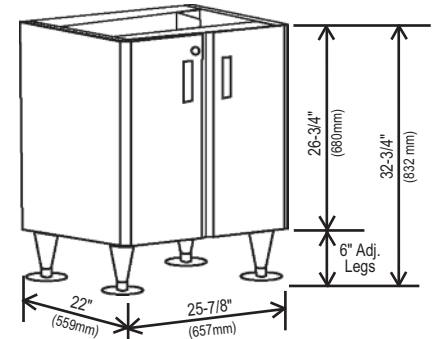

SD-500

## OPERATING LIMITS

- Ambient Temp Range 45 - 100°F
- Water Temp Range 45 - 90°F
- Water Pressure 10 - 113psig
- Voltage Range 104 - 127V

## SERVICE

- Panels easily removed and all components accessible for service.
- Removable/cleanable air filter.

TEL 1-800-438-6087

FAX 1-800-345-1325

www.hoshizaki.com

Printed in U.S.A.

